



AIRLIFT 320TL



The AIRLIFT 320TL is the most compact electric mobile crane available in the category on the market. In addition to the electric version the chassis allows different power sources :

- Electric on batterie only (one of the best range available for such equipment)
- Diesel engine and electric on batteries (option for 400 VAC)



TECHNICAL DATA

MAIN CHARACTERISTICS

| | |
|--|--------------------------|
| Sound power..... | 85 dB |
| Dimensions..... | 6 444 x 2 749 x 2 400 mm |
| Weight..... | From 17.350 kg |
| Max speed travelling..... | 12 kph |
| Max speed in travelling in pick and carry..... | 3 kph |
| Wheelbase..... | 3 570 mm |
| Steering radius in «coordonnée» mode..... | 4 000 m |
| Max slope while travelling..... | 5 % |
| Max cant while travelling..... | 3° |

TRANSMISSION

| | |
|---------------------------|--------------|
| Electric motor power..... | 22 kW |
| Driven wheels..... | 4 |
| Tyres..... | 9.00 R20 160 |

BATTERIES

| | |
|---------------------------|--------|
| Nominal voltage..... | 72 V |
| Capacity per battery..... | 465 Ah |

CRANE

| | |
|------------------------------------|------------------------------|
| Control station..... | Remote control or in the cab |
| Max lifting capacity..... | 6 T |
| Max reach about crane axis..... | 10.5 m |
| Rotation torque of the turret..... | 32.9 T.m |
| Lifting torque..... | 32 T.m |
| Ring diameter..... | 1 050 mm |
| Work pressure..... | 225 bars |
| Working area..... | 360° |
| Number of telescope..... | 3 hydraulic telescopes |

Available in Roadrail mode.

DIMENSIONS

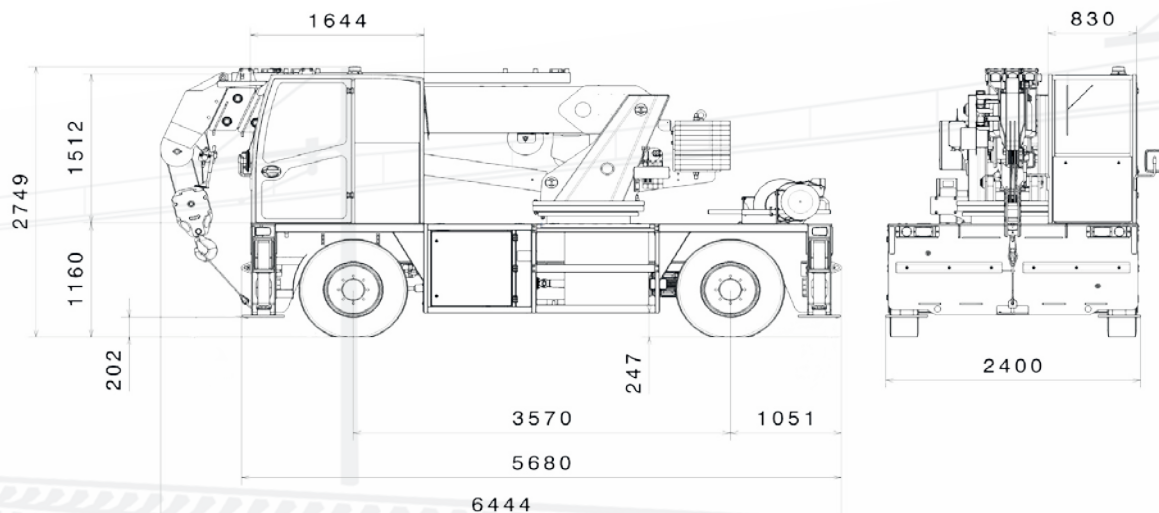

NEOTEC DÉVELOPPEMENT

275, impasse d'Umberti - 82710 Bressols - France

Tél : +33 5 63 02 95 95 - Fax : +33 5 63 02 17 18 - info@neotec-france.com

SAS au capital de 243 200 € - SIRET 380 898 882 00036 - Code NAF 3020Z - N° TVA intracommunautaire FR89 380 898 882

www.neotec-france.com

